

Capsule Machine

Mark IV

FUN COLLECTION

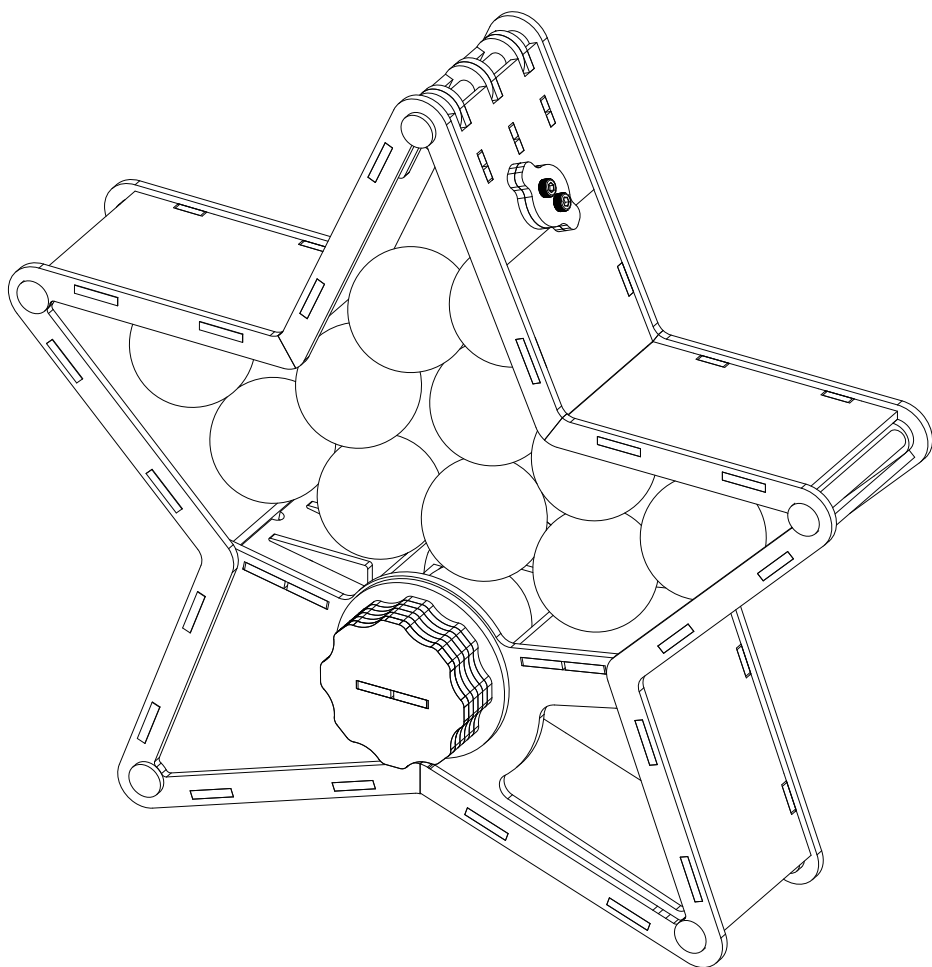

組裝影片
Assembly video



https://www.youtube.com/watch?v=8-ux8o_M9r8

Instruction

A1

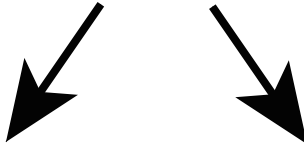

A木板
Board A

零件1
Part 1

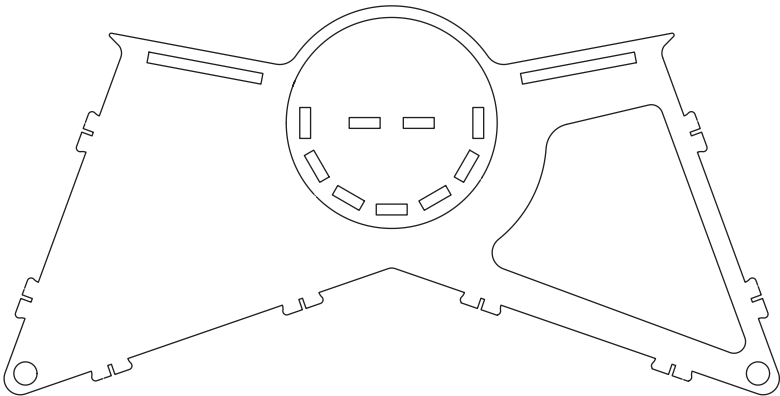

C1 B7 B8 E1 E2

本頁所需零件
Parts required on this page.
このページで必要なパーツ。



請注意C1零件正反面

Please pay attention to the front and back sides of part C1.
C1パーツの表裏にご注意ください。

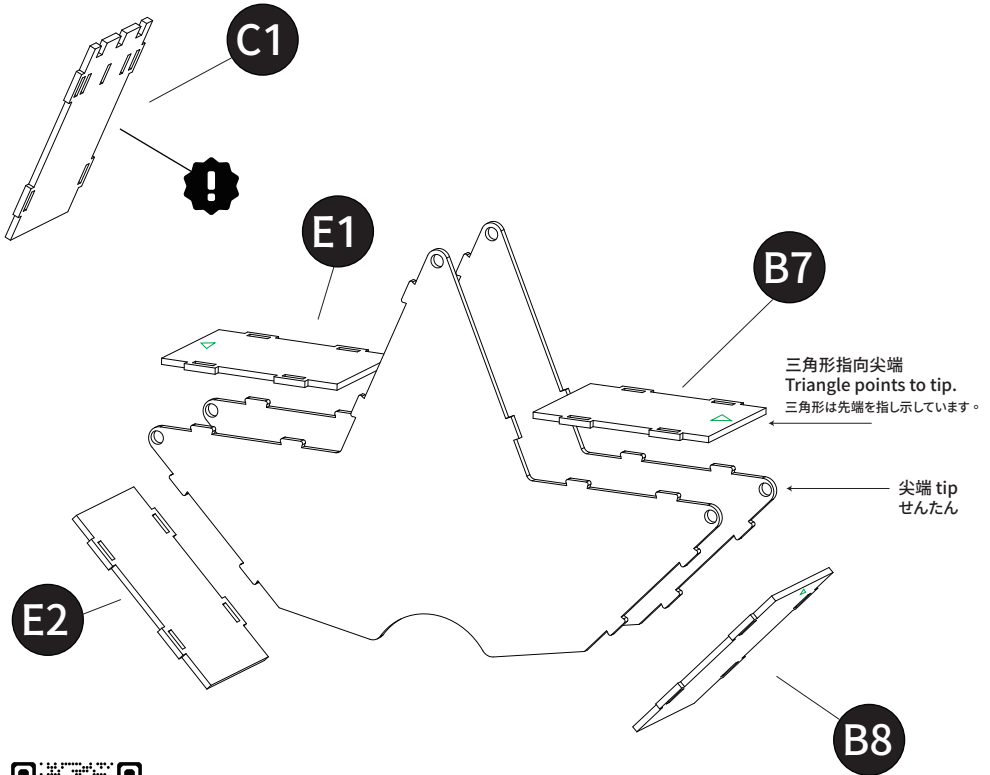

本頁步驟影片，請參考組裝施力方式。

The assembly video for this step is provided on this page.
Please refer to it for proper force application during assembly.

このページの手順動画をご覧いただき、組み立て時の力加減をご参考ください。

C9 x3



本步驟影片
Video for this step.
この手順の動画

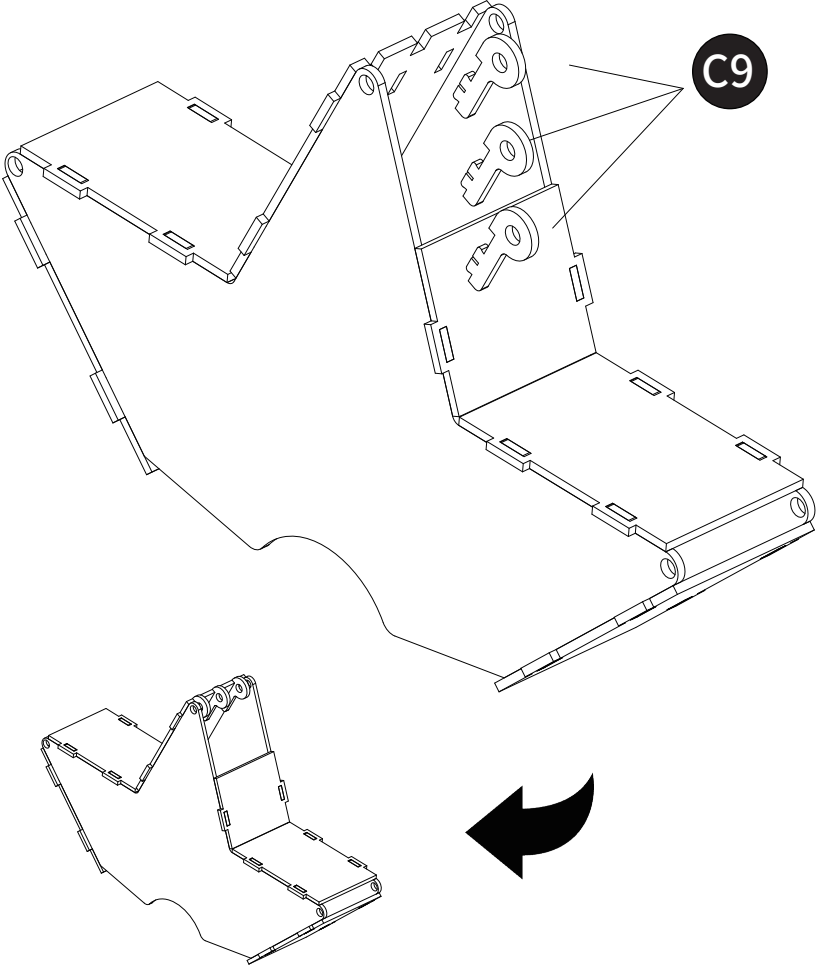

C7 C6 B6



本步驟影片
Video for this step.
この手順の動画

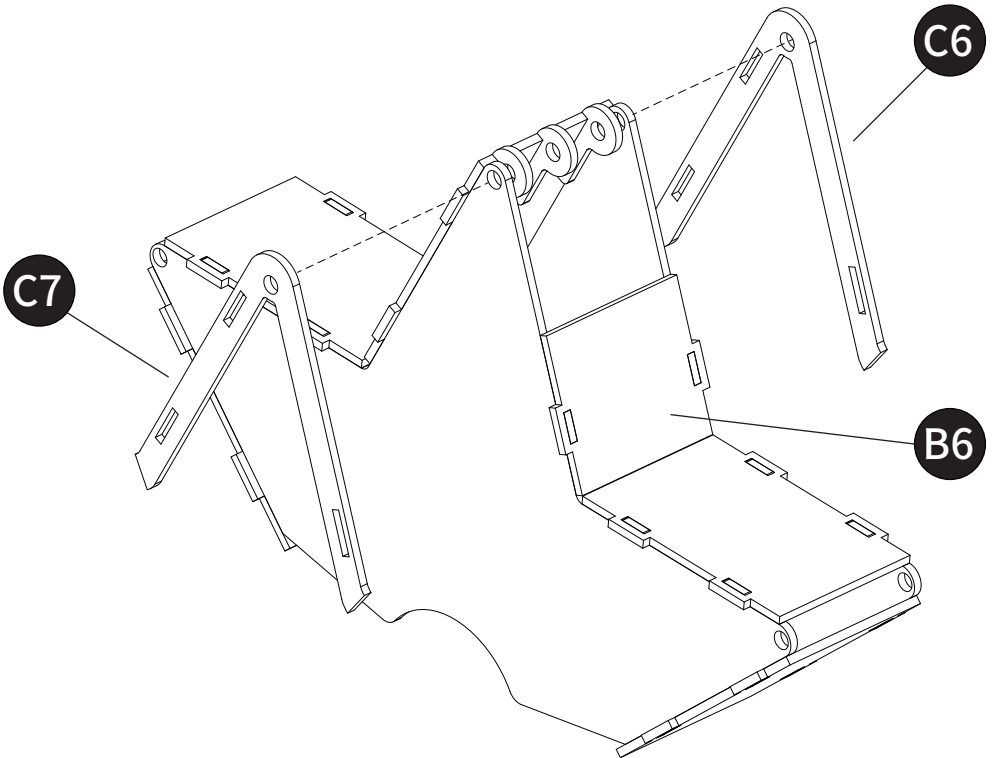

C9 B5



請注意B5零件正反面
Please pay attention to the front and back sides of part B5.
B5パーツの表裏にご注意ください。



本步驟影片
Video for this step.
この手順の動画

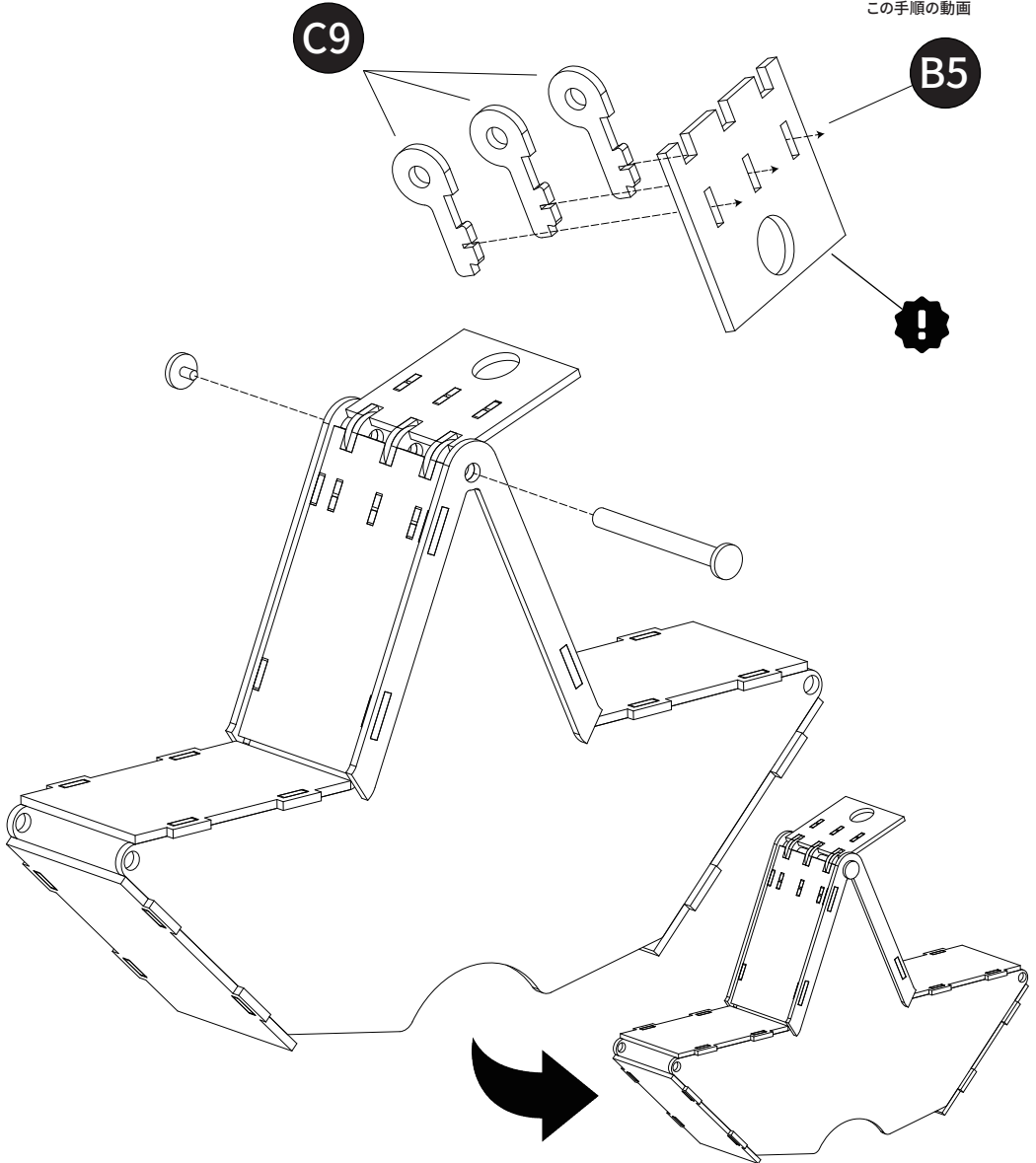

04

FunCollection.

E4

E5

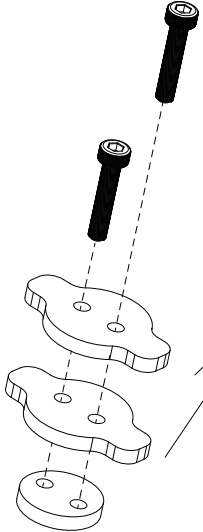
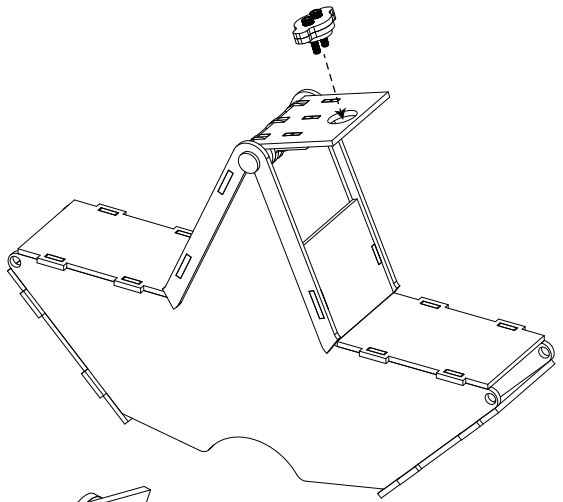

E4

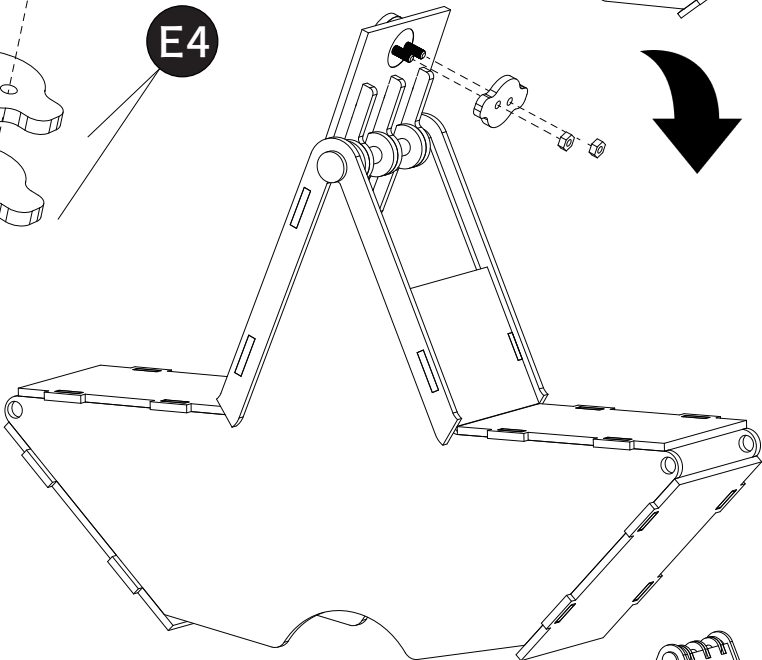

E5



本步驟影片
Video for this step.
この手順の動画

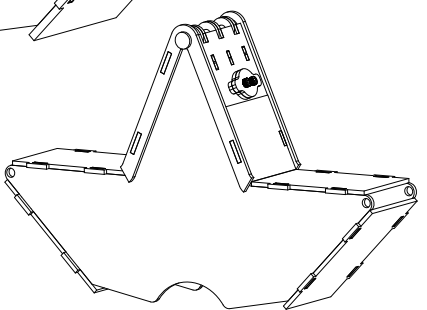
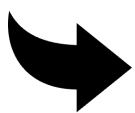

A1 A2 C4_{x7} A4

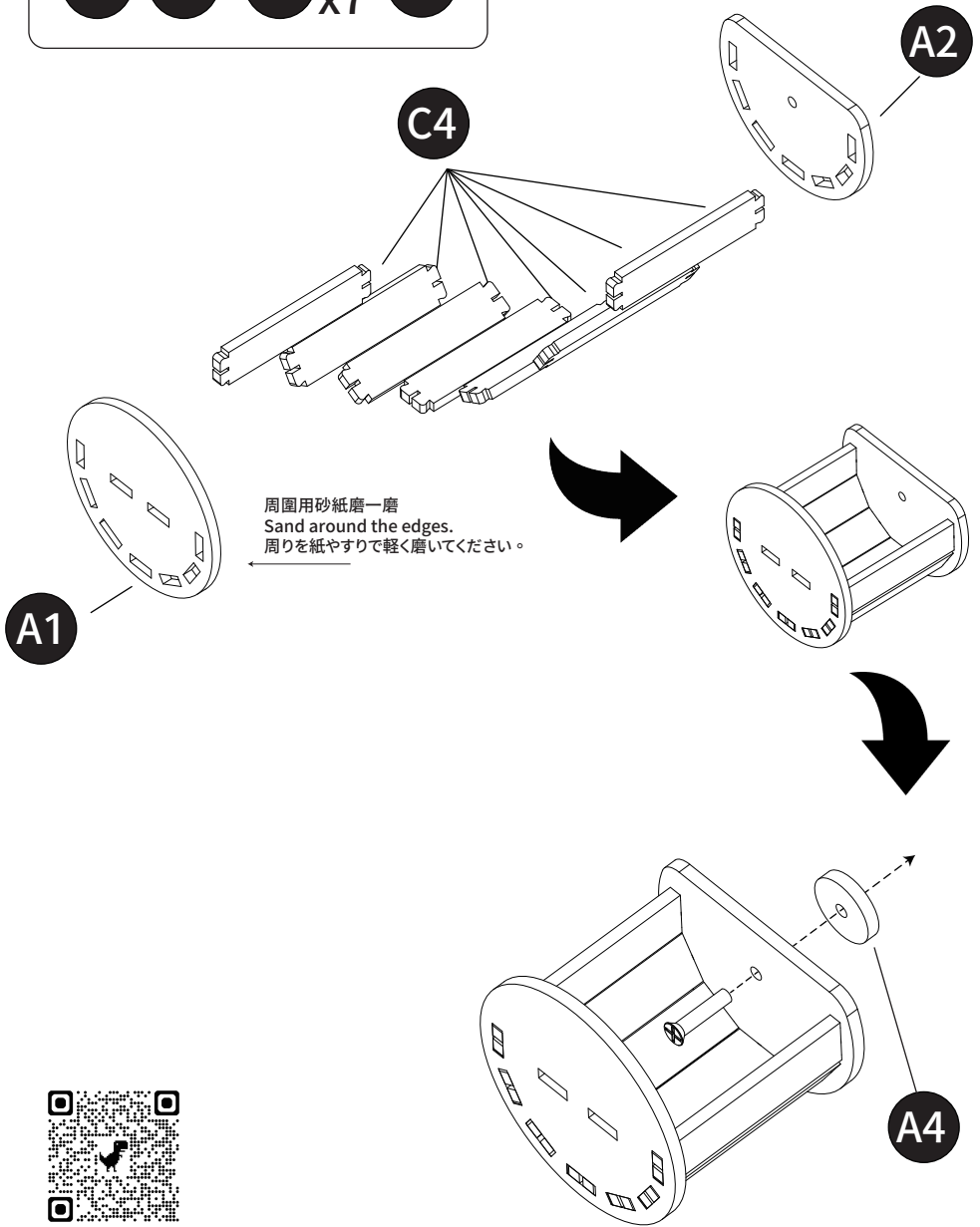

周囲用砂紙磨一磨
Sand around the edges.
周りを紙やすりで軽く磨いてください。



本步驟影片
Video for this step.
この手順の動画

- A3
- A6 x5
- C5
- D4



本步驟影片
Video for this step.
この手順の動画

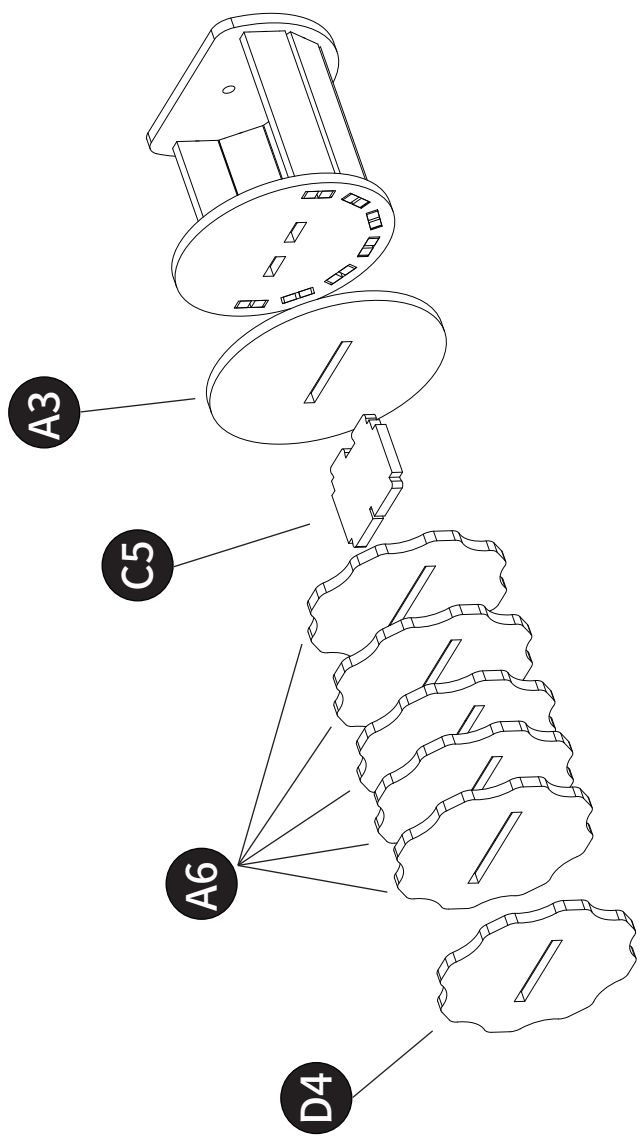

B1



本步驟影片
Video for this step.
この手順の動画

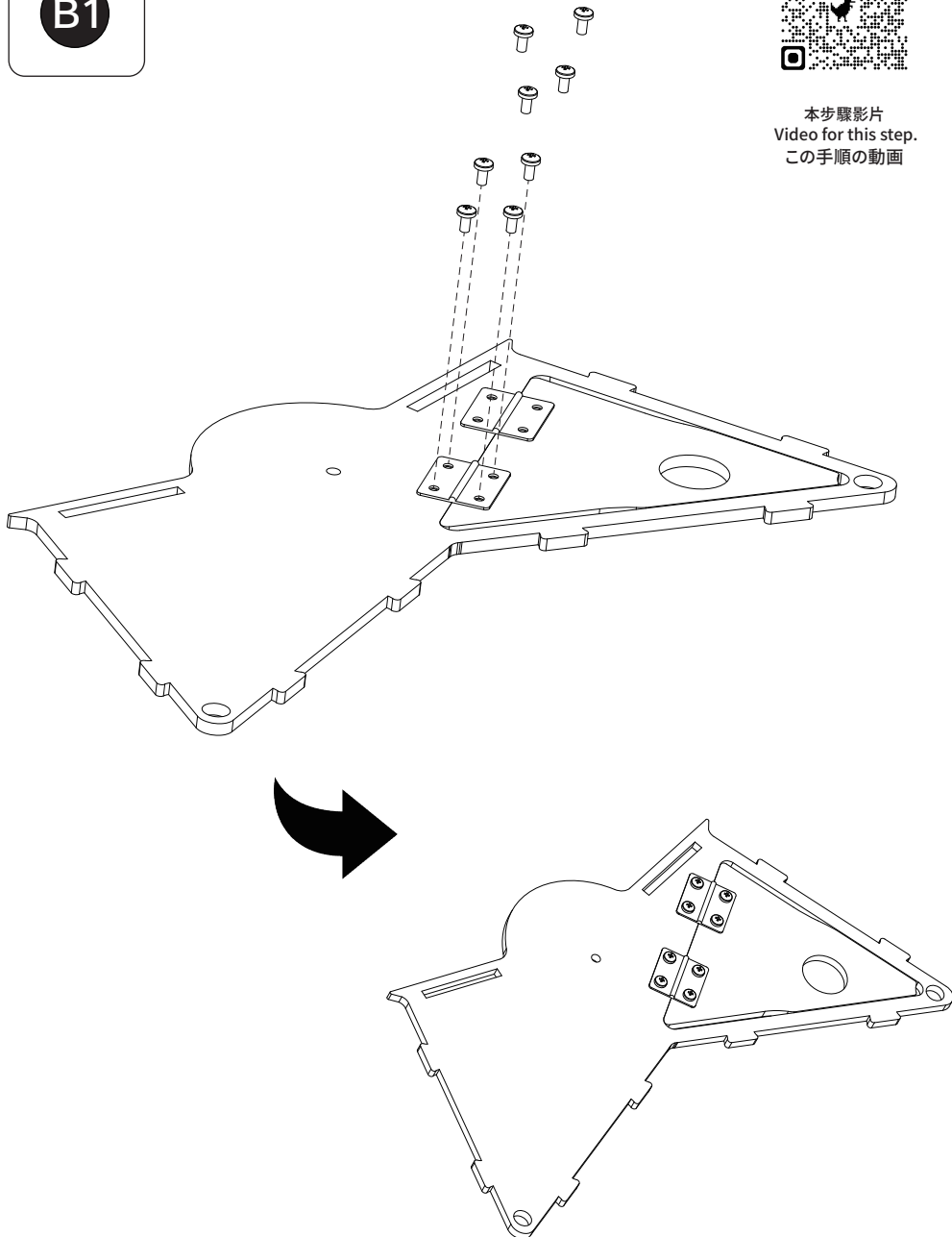

B2 B3 C8 x2



本步驟影片
Video for this step.
この手順の動画

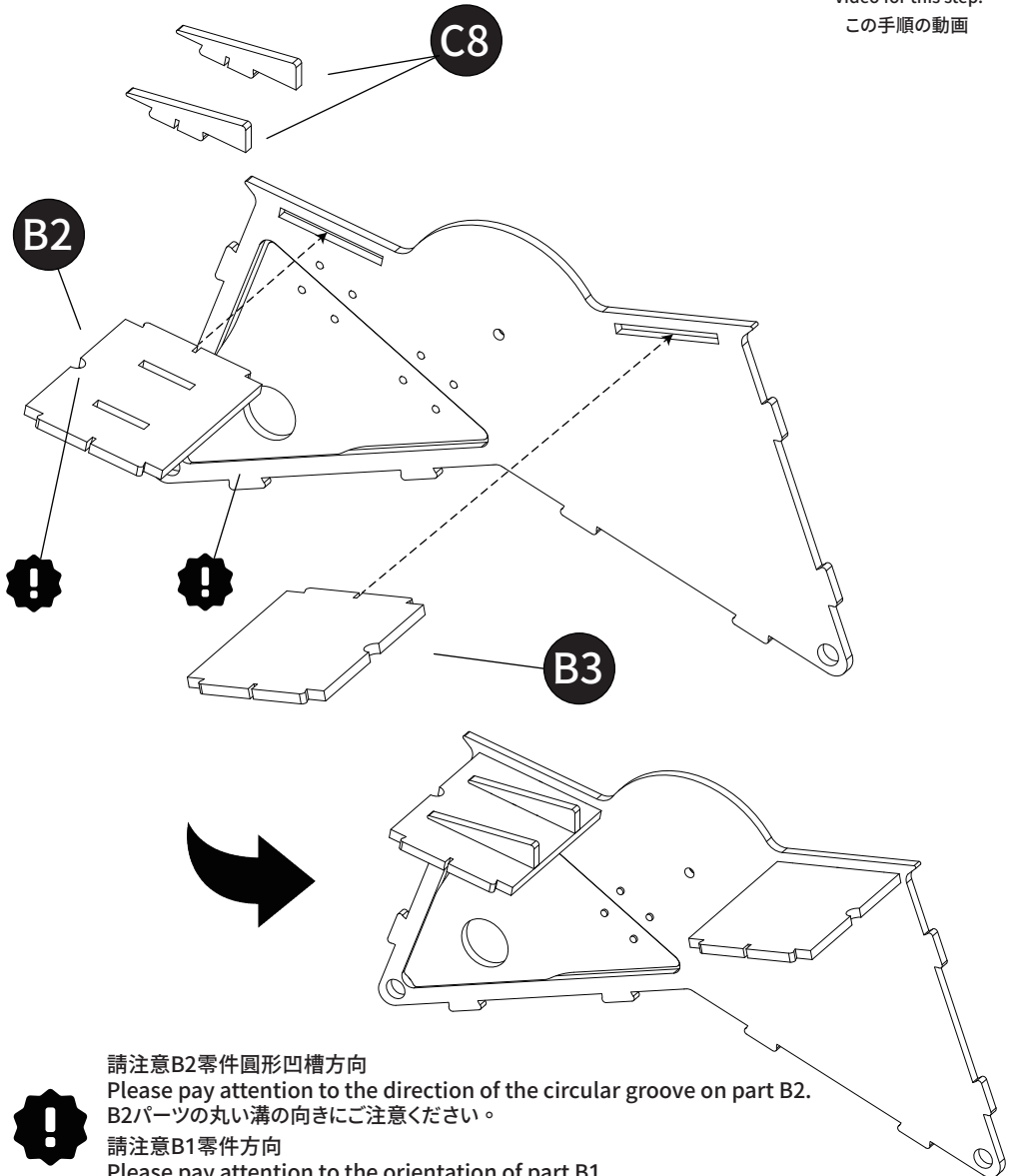

請注意B2零件圓形凹槽方向
Please pay attention to the direction of the circular groove on part B2.
B2パーツの丸い溝の向きにご注意ください。

請注意B1零件方向
Please pay attention to the orientation of part B1.
B1パーツの向きにご注意ください。



本步驟影片
Video for this step.
この手順の動画



請注意A1零件方向
Please pay attention to the orientation of part A1.
A1パーツの向きにご注意ください。

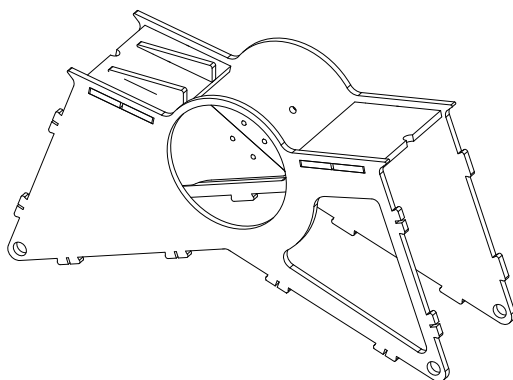
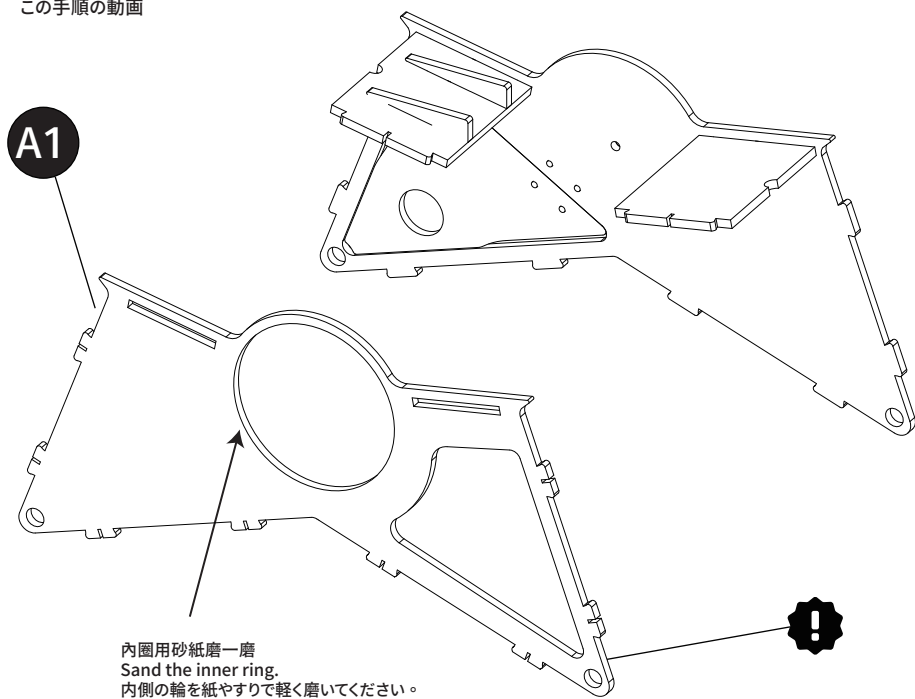

E3 B4 B9 C3 C2



本步驟影片
Video for this step.
この手順の動画

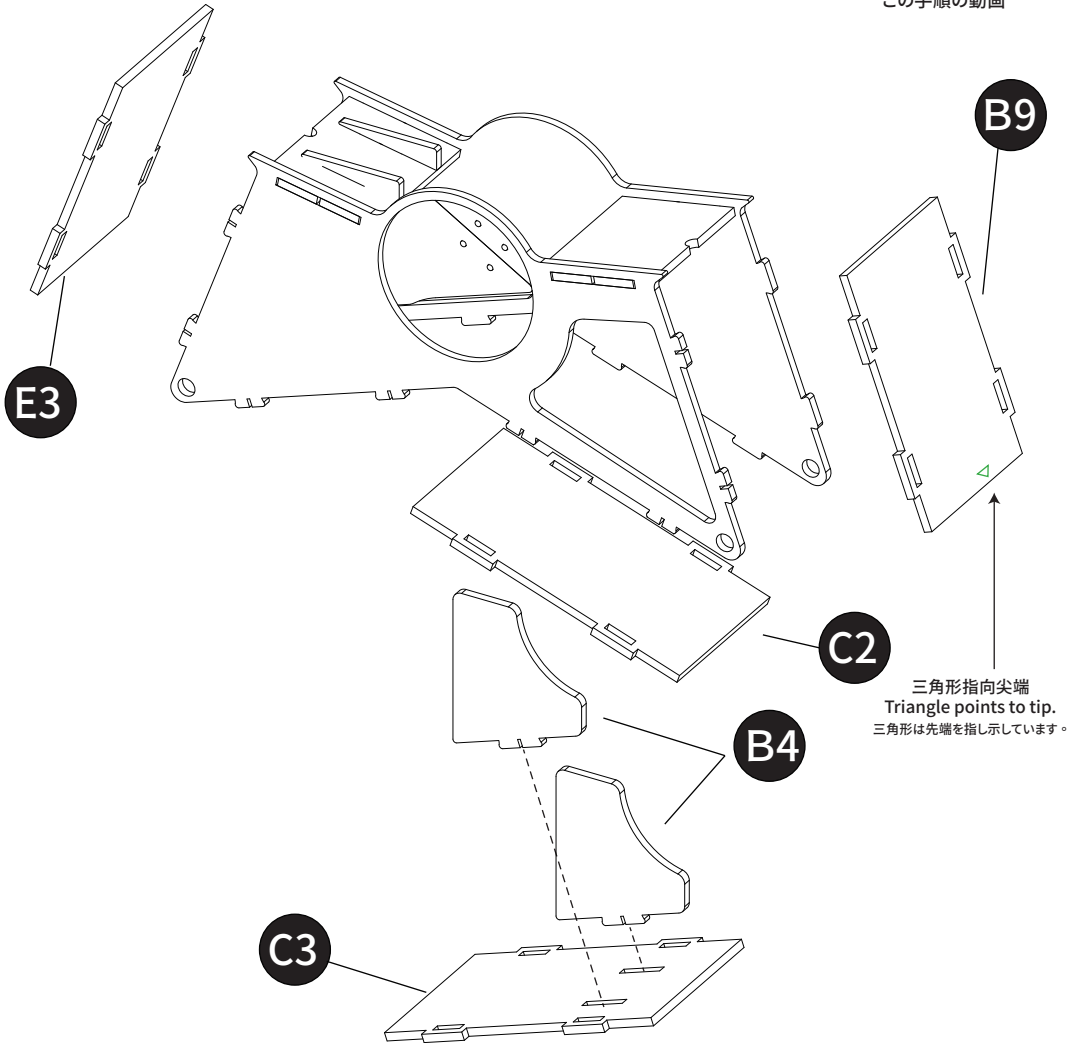

三角形指向尖端
Triangle points to tip.
三角形は先端を指し示しています。



請注意零件正反面

Please pay attention to the front and back sides of parts.
パーツの表裏にご注意ください。



本步驟影片
Video for this step.
この手順の動画

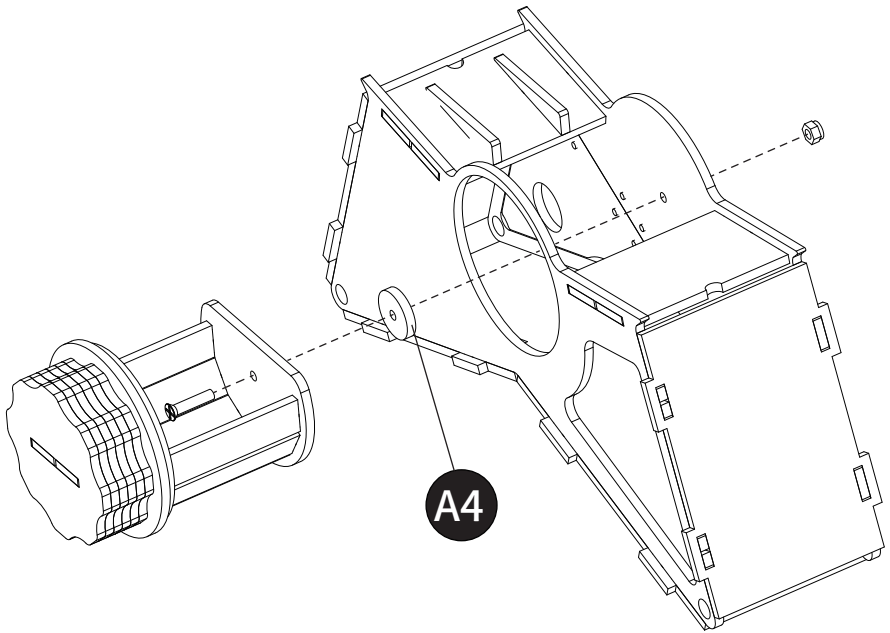



本步驟影片
Video for this step.
この手順の動画

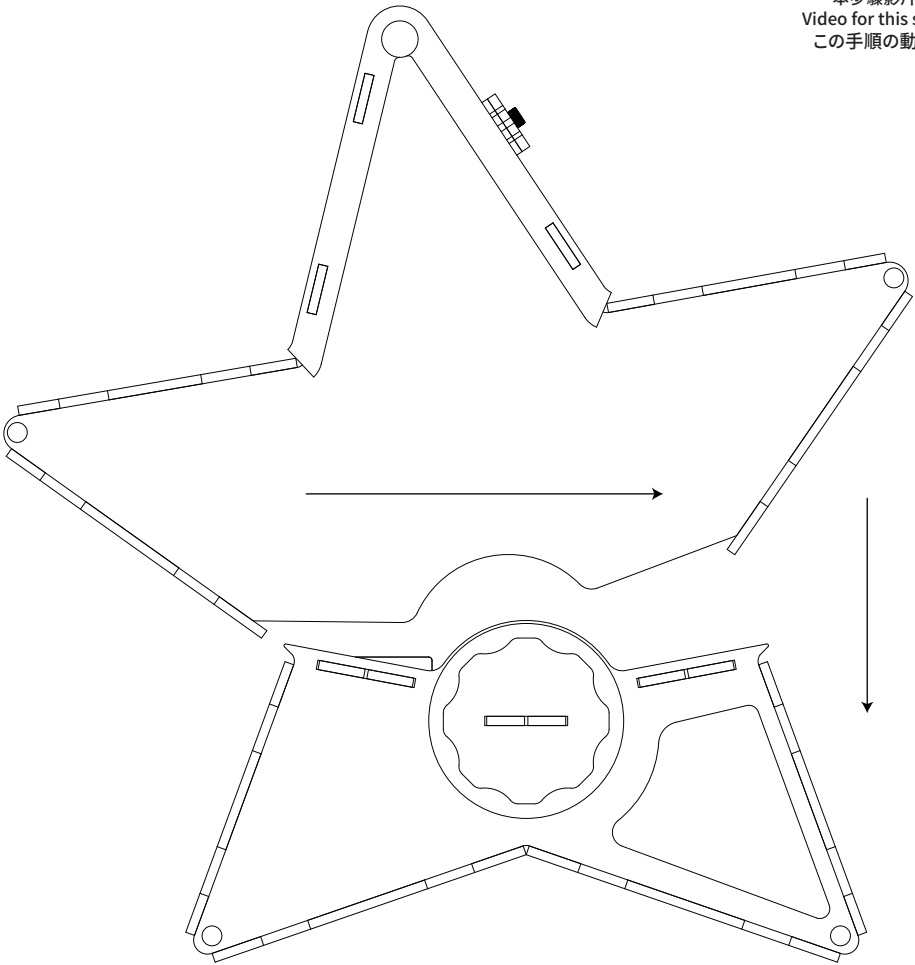

請參考影片組裝方式

Please refer to the video for the assembly method.
動画を参考にして組み立ててください。



本步驟影片
Video for this step.
この手順の動画



燈串安裝方法
String Light Installation Method
ライトストリングの取り付け方法。

FunCollection.

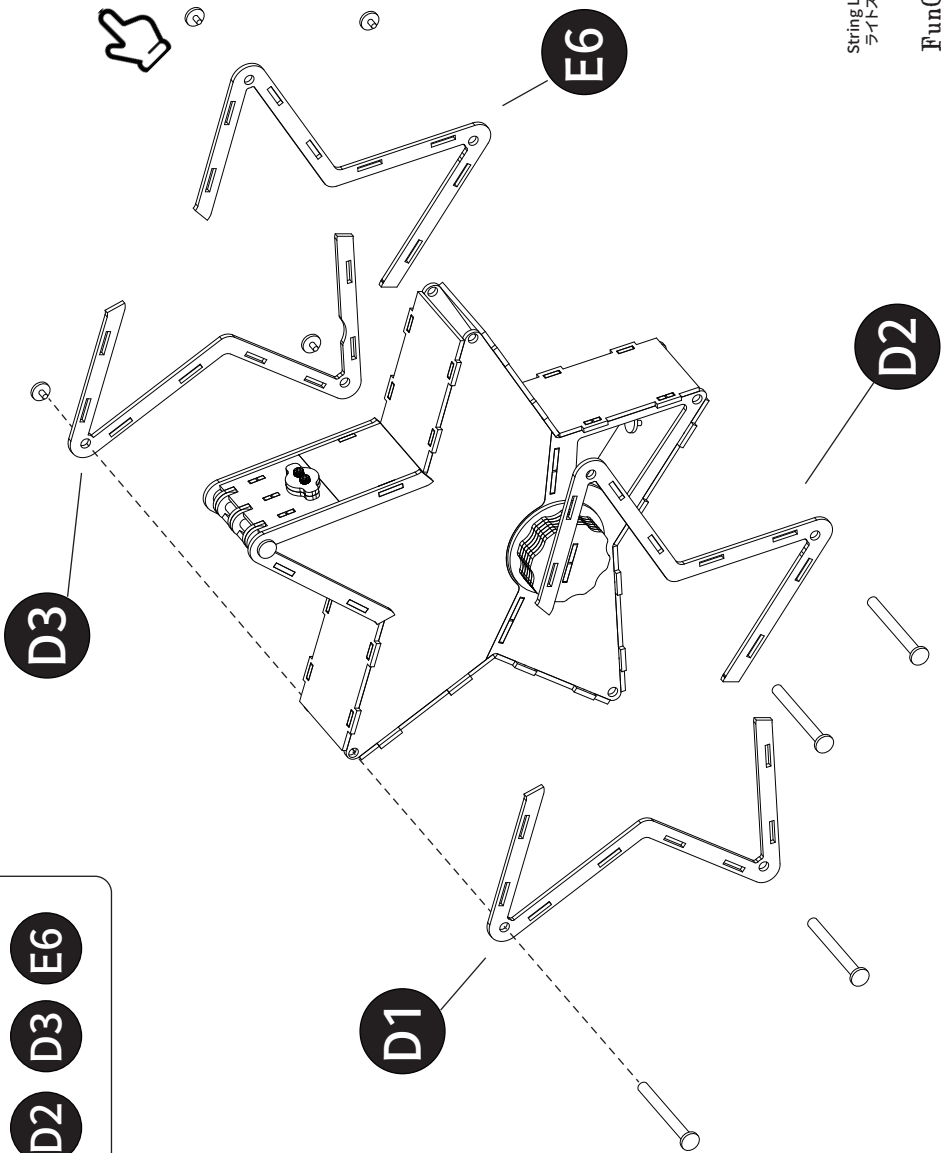



開扭蛋的方法
How to Open the Capsule.
ガチャの開け方。

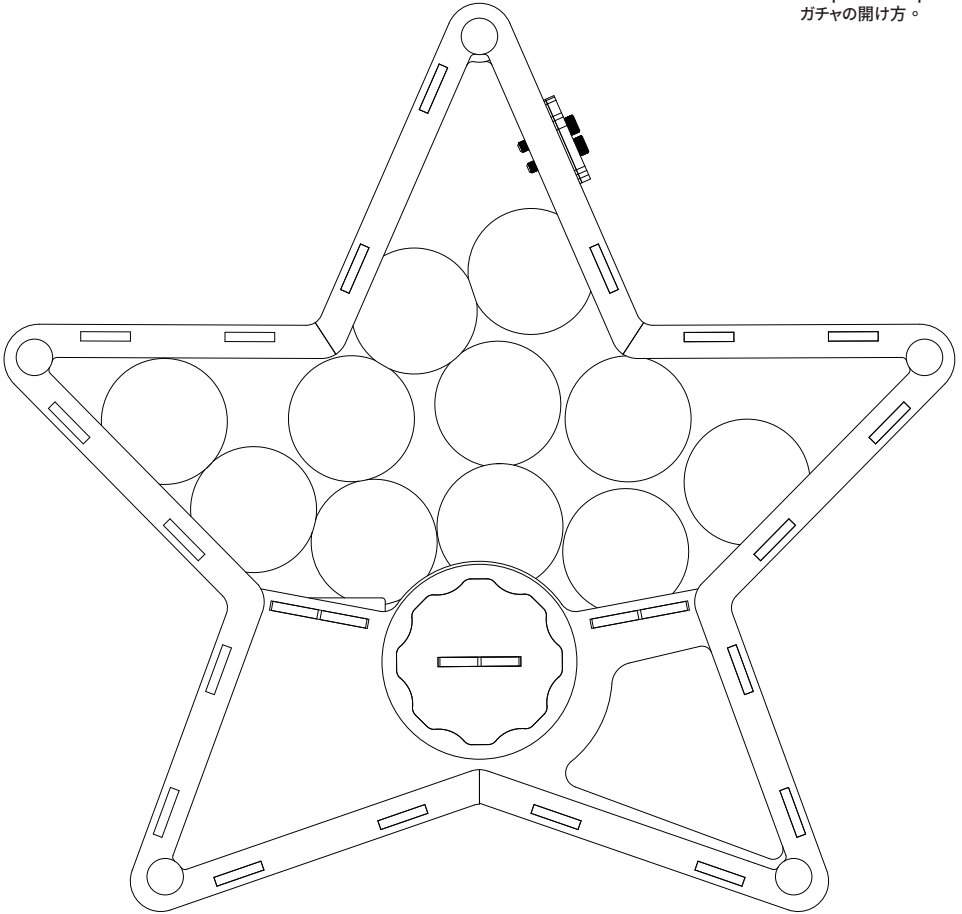

完成
Finish.

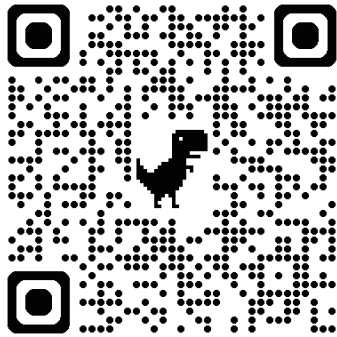

www.fanggu.org